

## INSTALLATION STEPS 68-82 HEADLIGHT MOTOR UPGRADE KIT

Thanks for ordering your upgrade kit, please read through these steps to get a feel for what's going on and how really simple the installation is!

1. **REMOVE** the hood and the two turn signal/front grills, 68-79; refer to drawings for your year Vette. **NOTE:** on 80-82 no need to remove grills, you will be accessing the headlight door springs and linkages from underneath the front bumper area, **CAUTION;** when using a floor jack, please use jack stands for safety.
2. **REMOVE** both vacuum lines on each headlight vacuum canister, manually raise both headlight assemblies and lock in place by pushing the actuator link toward the back of the car, see Drawing #1.
3. **REMOVE** the small vacuum hose (white stripe) that goes to the vacuum relay(s) located in the center under the front nose of the car, plug with the solid rivet provided.
4. **REMOVE** the 4 springs on each headlight actuator assembly. Drawing #1, items 6 and 7
5. **REMOVE** the cotter pin on the pin shaft that holds the rod end clevis in the actuator assembly and slide it out, paying attention to the plastic bushings and washers, this rod and rod end will be reinstalled later, Drawing #2, item 6
6. **REMOVE** the 4 nuts on each vacuum canister and remove the vacuum canisters.
7. **INSTALL** the 5/16" bolts and speed nuts (provided) to secure the outboard brace rod back to the actuator assembly housings, one on each assembly, Drawing # 1, item 4
8. **REMOVE** the rod end clevis from the vacuum canister push rod, these will probably be stuck, vise grips on the rod and crescent wrench will take care of this.
9. **REINSTALL** the rod end clevises back in the headlight actuator link on the small pin shaft and cotter pins, making sure all the plastic bushings, washers, and springs are back where they started out, Drawing #2, items 4,5,6,7,13,12 – Reattach springs Drawing #1, items 6 and 7
10. You will notice that this rod end and pin shaft fits into curved slots on the actuator link, **INSTALL** the 5/16" x 1 1/2" bolt and speed nut (provided) in the forward area of the slot, **DO NOT TIGHTEN, THESE ARE FLOATERS THAT WILL ONLY LIMIT THE MOVEMENT OF THE ORIGINAL ROD END IN THE SLOTTED AREA.**

11. Locate the vacuum holding tank, under the fender on the LH side at firewall, locate the large vacuum hose (yellow stripe) that goes forward along the LH fender, remove this line from the vacuum tee fitting and cap the tee with the vinyl push on cap (provided)

12. **INSTALL** the LH and RH motors (LH and RH stamped on the motor mounting bracket) using the speed nuts provided. **DO NOT ROTATE THE MOTORS WITH THE MANUAL TURN UP KNOBS ON THE MOTOR ENDS; THESE ARE FACTORY SET FOR THE HEADLIGHT DOWN ADJUSTMENT.**

**INSTALL** the new LH and RH motor assemblies in the two inboard holes where the vacuum canisters were removed from, the actuator levers on the motors will face out, and the manual turn up knobs on the motors will be pointing down. Make sure to reinstall the **in-board** original rod braces behind the mounting plates on the lower studs of the new motor mounts, secure with the speed nuts provided. See Picture # 2 and 3 for reference.

13. **ROUTE** the motor wires along of the blank side of the motor (**not** actuator lever side) and secure along the existing wire/vacuum hose harness under the front nose to the LH side of the car (snap ties provided), continue beside the left hand hood hinge and the body into the area beside the radiator. When this wire connector is installed in the control module you can use snap ties to secure the new wire harness. See Picture # 2 and 3 for reference.

14. Manually lower the headlight assemblies by pulling forward on the actuator link in the area you pushed backward to lock earlier.

15. **SCREW** the new actuator rods with ball ends into the original rod ends that you reinstalled on the pin shafts earlier, leave about a 1/4" of thread exposed. Install one washer on the new motor lever shafts. Try to line up and push the ball ends onto the lever shafts. Screw the rods in or out as needed, when they will go on, take a **half turn clock wise and reinstall**. Install a washer and the clevis clip (provided) on each actuator to secure. See picture # 2 and 3.

16. **NOW** would be a good time to oil the pivot points on the original headlight assemblies, especially in the area where the springs were removed, Blaster Corrosion Stop is good, or any lithium base lubricant.

17. **REMOVE** the left front wheel. **CUT** out the template along the solid lines to use for drilling the holes to mount the actuator module.

18. Position the template along the LH lower wheel house edge, push back the template until it is along the edge of the bump out that the upper control arm splash guard secures to. (See picture # 1 for clarity)



19. Using a 1/8" drill bit, carefully drill two pilot holes at the "+" marks on the template, follow them up with a 5/16" bit to finish, **PLEASE DON'T DRILL DEEP THE RADIATOR IS RIGHT THERE, AND THERE ALSO MAY BE OPTIONAL WIRING HARNESES THAT MAY HAVE TO BE MOVED.**

20. Your actuator module will come with the new main harness already connected. Bring the module over to the LH front side, route the motor wires carefully beside the left hood hinge and the body, connect the motor wire harness, 4-pin connector, making sure it locks into the module. This connector in the module should face up when you push the module into position. Slide the module down between the wheel house and the radiator and attach to the wheel house using the plastic push pins provided, see Picture # 4.

21. Route the brown single wire coming out of the main 5-pin connector (already plugged into the module), thru the factory wire harness access hole beside the radiator and down toward the LH side marker light, find the brown wire going into the side marker light, this will have 12V only when the lights are on, probe with a test light with the headlight switch **ON** if you are unsure of the color, **THEN TURN THE HEADLIGHT SWITCH OFF (POWER SHOULD GO OFF)**. Using the wire splice provided, position the splice so the car wire will go through the splice, then push the new brown wire into the splice to the stop, use pliers to squeeze the metal part through the wires, bring the plastic tab over the top and lock, dielectric grease has been used here to help prevent corrosion.

**22. PLEASE! DISCONNECT THE NEGATIVE BATTERY TERMINAL.** Install the red wire terminal on the red wire terminal on the alternator; install the black wire terminal on the black wire terminal on the alternator. Secure the wires along the car harness with the snap ties provided.

23. Reconnect the battery, you may hear some headlight motor movement, pull your headlight switch all the way on until the motors stop running, now push the headlight switch off, this will orient the module. Good Job, Enjoy!

24. Reinstall the wheel, hood, and grills.

# DRAWING # 1

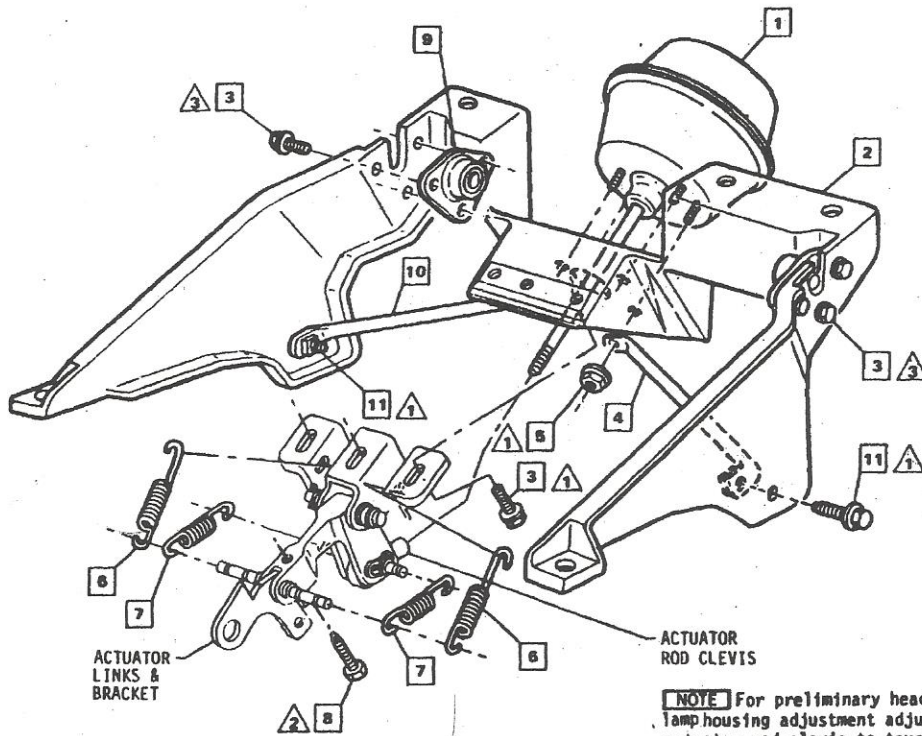

- |           |    |                                     |
|-----------|----|-------------------------------------|
| 5638541   | 1  | ACTUATOR ASM RH                     |
| 5638542   | 1  | LH                                  |
| 347889-0  | 2  | SUPPORT L & RH                      |
| 3846201   | 3  | BOLT/SCREW                          |
| 3926353-4 | 4  | ROD ASM-ACTUATOR<br>OUTBOARD L & RH |
| 1359887   | 5  | NUT                                 |
| 3935516   | 6  | SPRING                              |
| 3926434   | 7  | SPRING                              |
| 473239    | 8  | BOLT/SCREW-ADJ                      |
| 362995    | 9  | BEARING ASM                         |
| 3926351-2 | 10 | ROD ASM-ACTUATOR<br>INBOARD L & RH  |
| 3847757   | 11 | BOLT/SCREW                          |

**NOTE** For preliminary headlamp housing adjustment adjust actuator rod clevis to touch condition at forward end of slot, then add 1/2 turn more to give approx. .03 interference condition with lamps on.

**NOTE** For final headlamp housing adjustment use screw asm item 8 and fit to checking dimensions specified on UPC 112 Sheet 1.

# DRAWING # 2

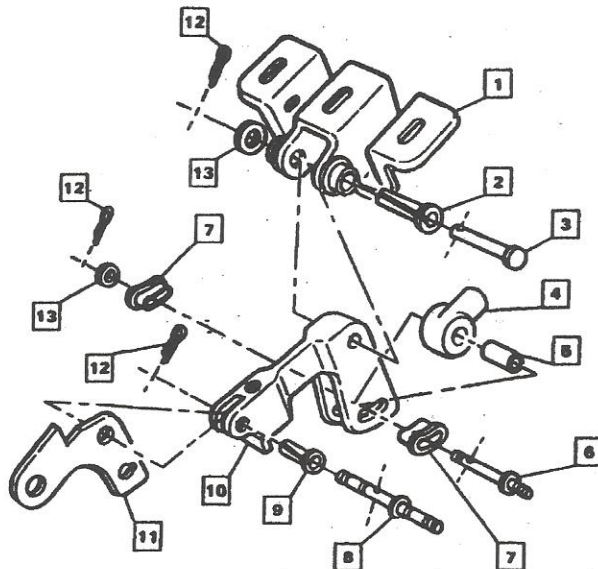

- |         |    |            |
|---------|----|------------|
| 3922499 | 1  | BRACKET    |
| 3927674 | 2  | BUSHING    |
| 3927676 | 3  | PIN        |
| 3958887 | 4  | ROD-CLEVIS |
| 3922498 | 5  | SLEEVE     |
| 3927672 | 6  | PIN        |
| 3922497 | 7  | INSERT     |
| 3926433 | 8  | PIN        |
| 3927675 | 9  | BUSHING    |
| 461162  | 10 | LINK       |
| 3953034 | 11 | LINK       |
| 456170  | 12 | C. PIN     |
| 3825452 | 13 | WASHER     |



68-69

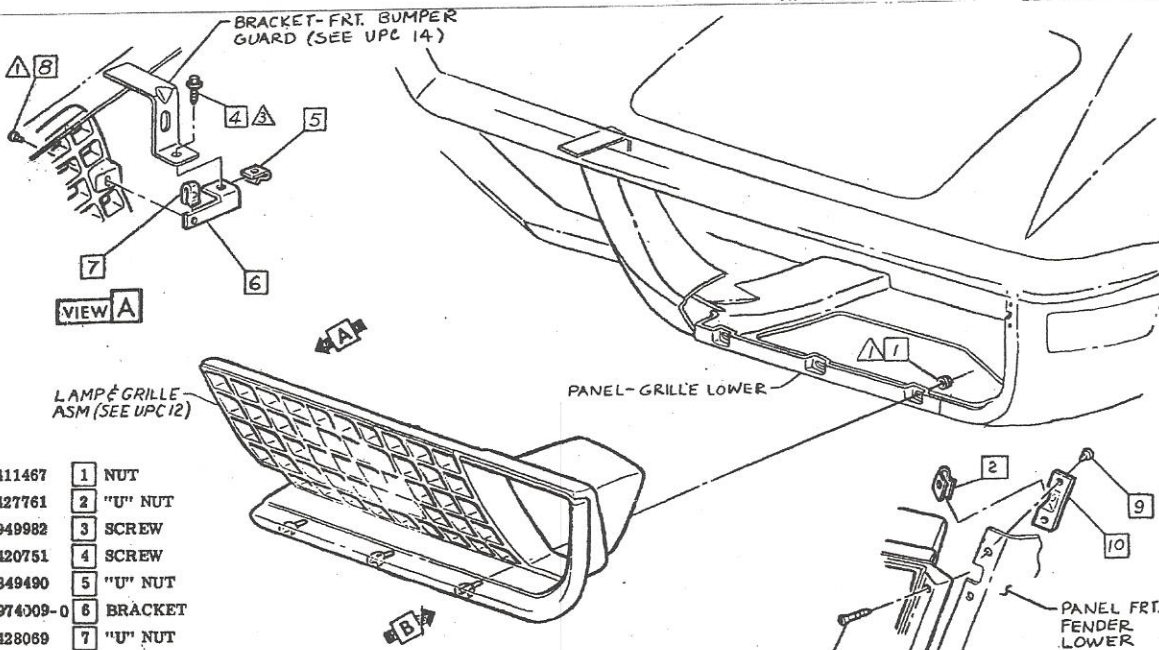
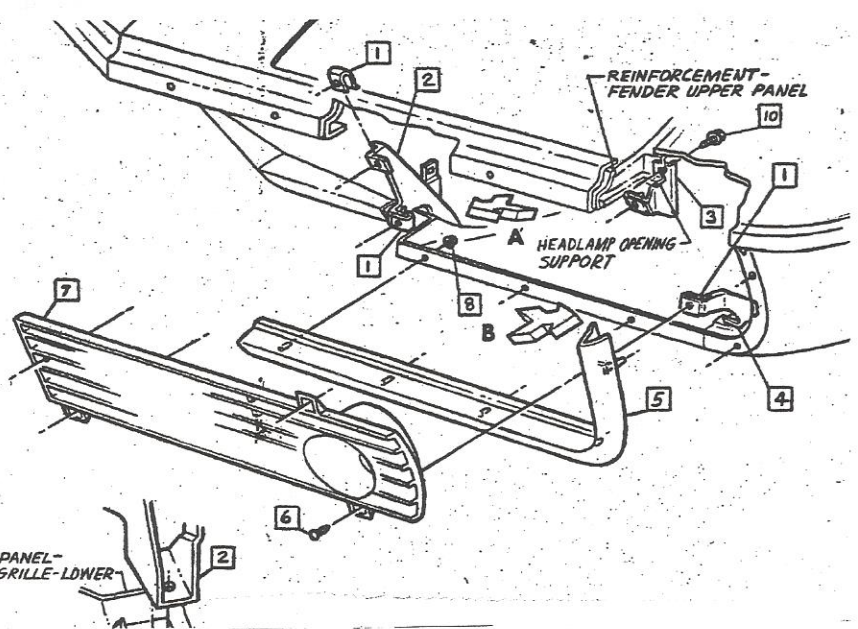

- 9411467 1 NUT
- 9427761 2 "U" NUT
- 3949982 3 SCREW
- 9420751 4 SCREW
- 3849490 5 "U" NUT
- 3974009-0 6 BRACKET
- 9428069 7 "U" NUT
- 9427651 8 SCREW
- 3828547 9 RIVET
- 3976359-0 10 BRACKET

70

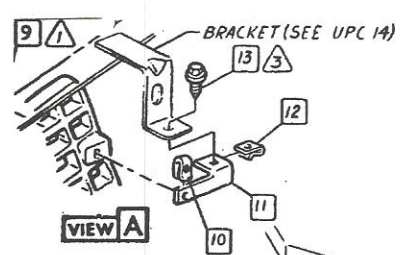
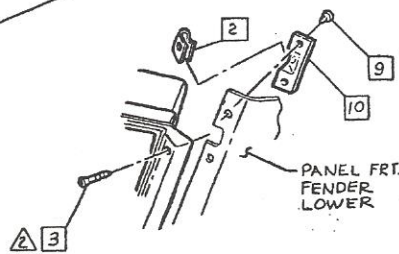

- 3963133-4 1 SUPPORT
- 3846854 2 "U" NUT
- 9420137 3 "J" NUT
- 3927360 4 "U" NUT
- 3828548 5 RIVET
- 3976359-0 6 BRACKET
- 3949982 7 SCREW
- 3966772 8 GRILLE
- 9427651 9 SCREW
- 9428069 10 "U" NUT
- 3974009-0 11 BRACKET
- 3849490 12 "U" NUT
- 9420751 13 SCREW
- 3846988 14 SCREW

71-72

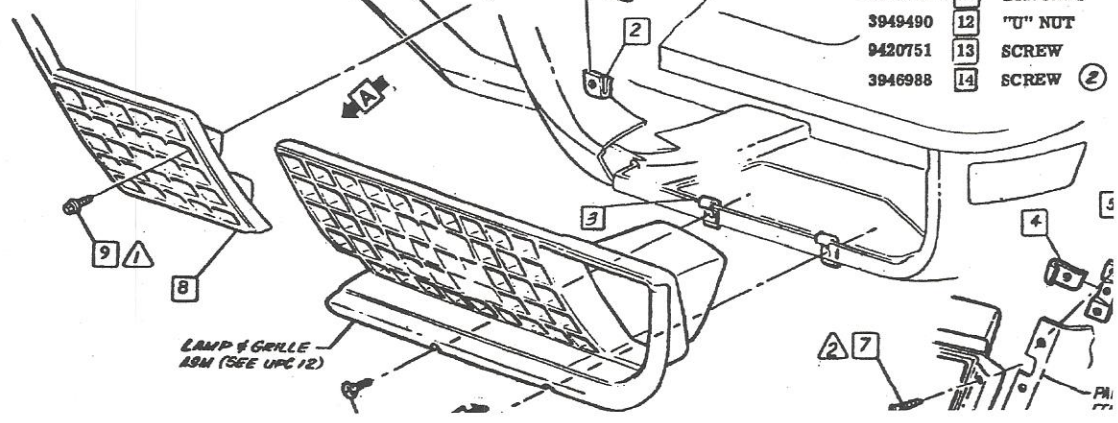

73-74

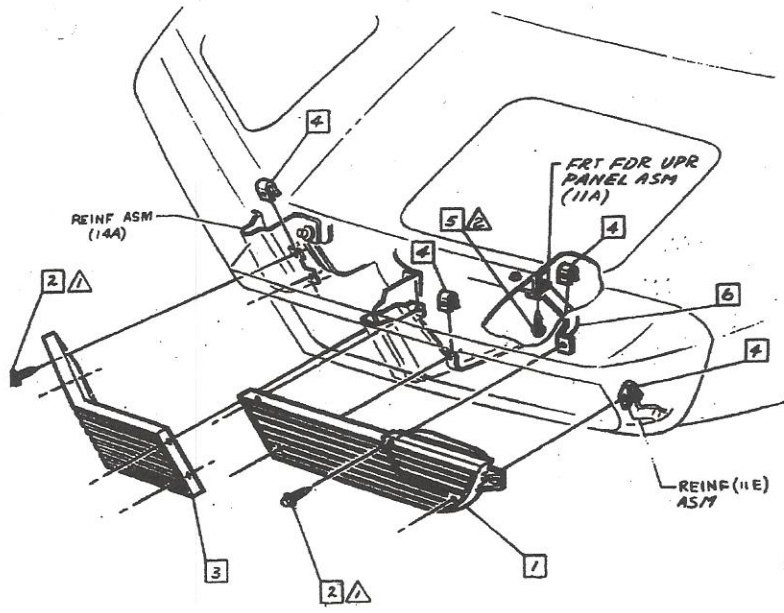

- 331835-6 1 GRILLE-OUTER
- 9427651 2 SCREW
- 331834 3 GRILLE-CENTE
- 3848854 4 "J" NUT
- 3797168 5 SCREW
- 331859-0 6 BRACE

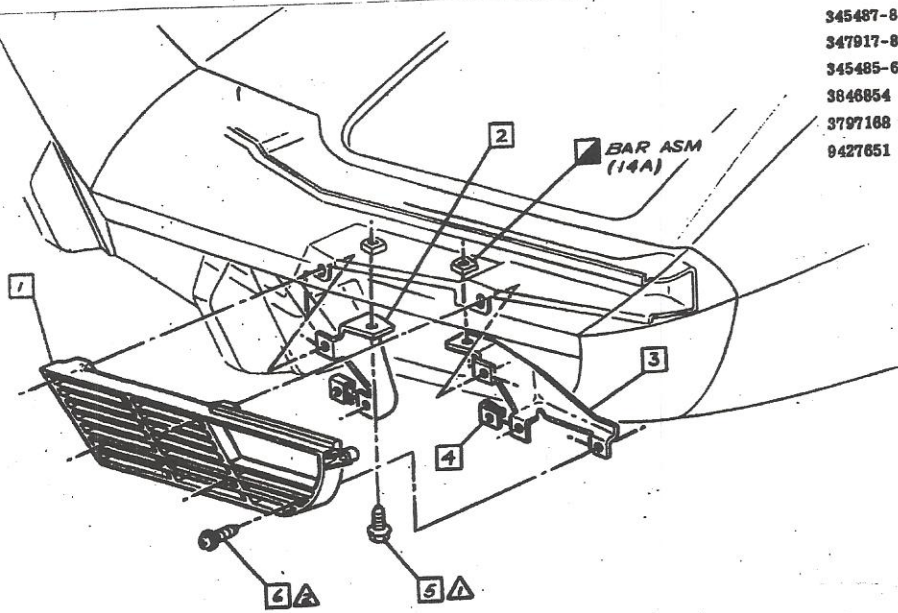

- 345487-8 1 GRILLE-RAD
- 347917-8 2 BRACKET-INNER
- 345485-6 3 BRACKET-OUTER
- 3848854 4 "J" NUT
- 3797168 5 SCREW
- 9427651 6 SCREW

75-79



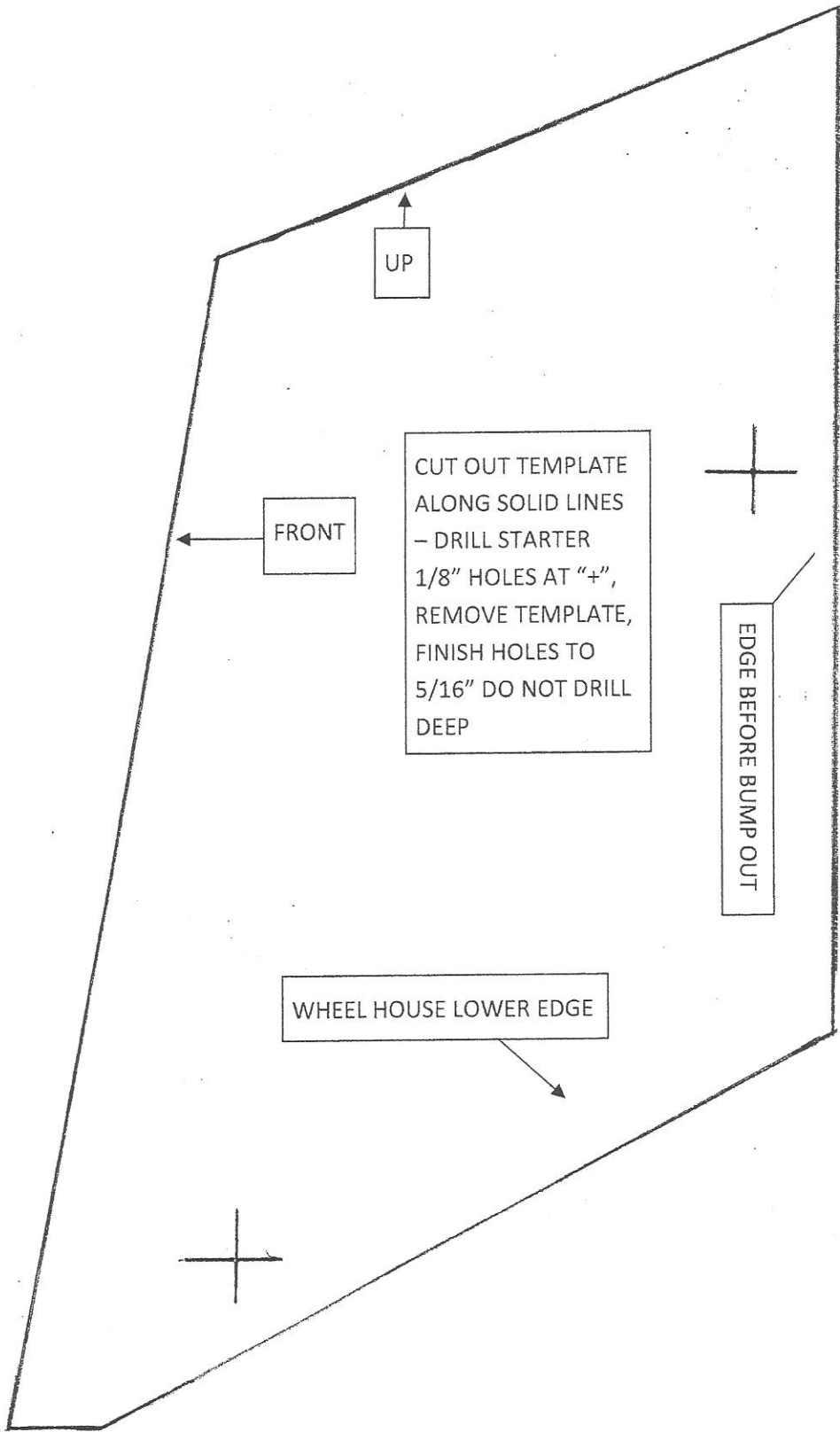

UP

FRONT

CUT OUT TEMPLATE  
ALONG SOLID LINES  
- DRILL STARTER  
1/8" HOLES AT "+",  
REMOVE TEMPLATE,  
FINISH HOLES TO  
5/16" DO NOT DRILL  
DEEP

EDGE BEFORE BUMP OUT

WHEEL HOUSE LOWER EDGE







Picture #2 (LH)

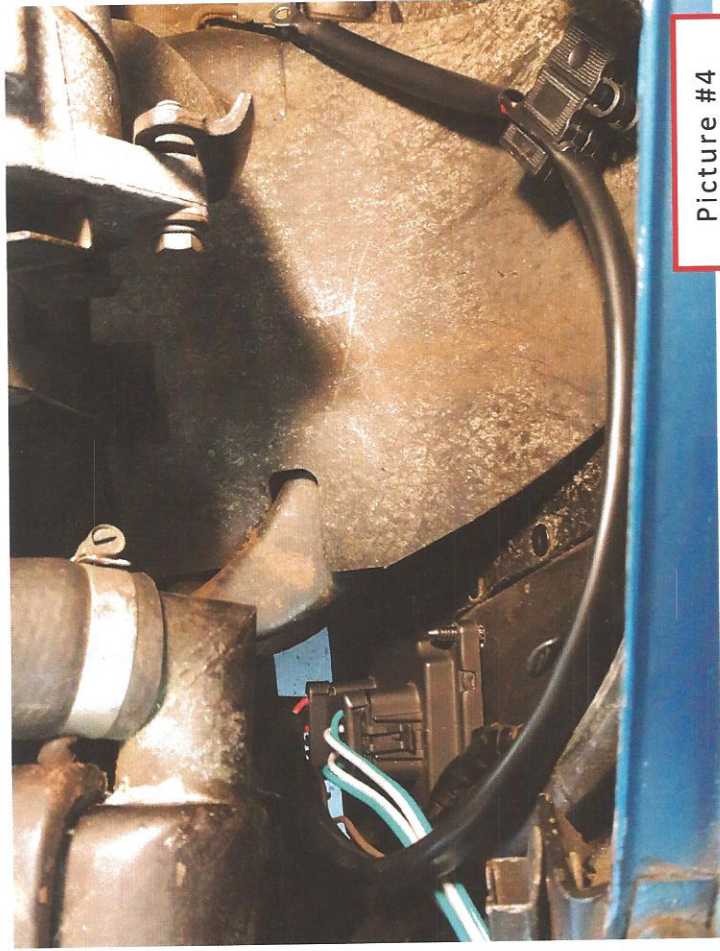

Picture #4

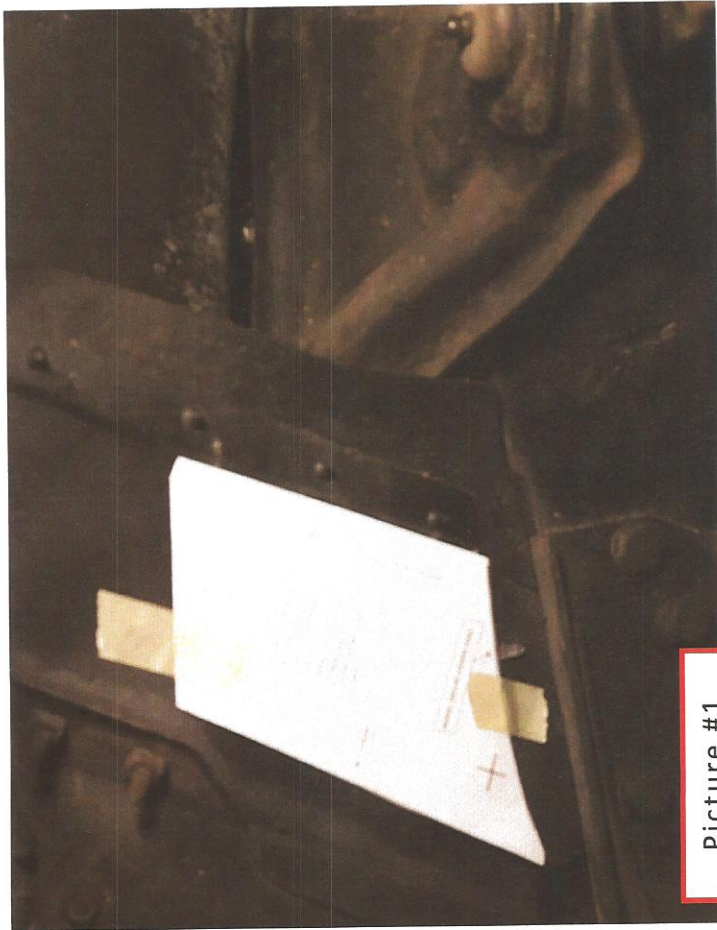

Picture #1



Picture #3 (RH)